

102 ft. span tip

Aircraft skin: .0005" Mylar

transport breaks

All-moving tip aileron

balsa tip structure

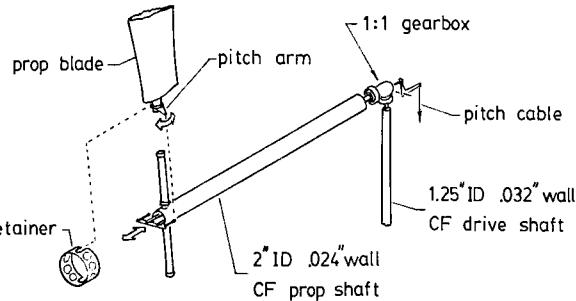

Kevlar X-bracing
3.50"-2.25" ID CF tailboom

freewheeling prop
airspeed sensor

All-moving tail surfaces

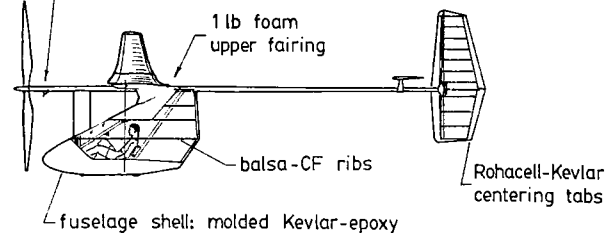

1.25"-1.0" ID CF tail spars

11 ft. dia. prop.
115 rpm at design pitch

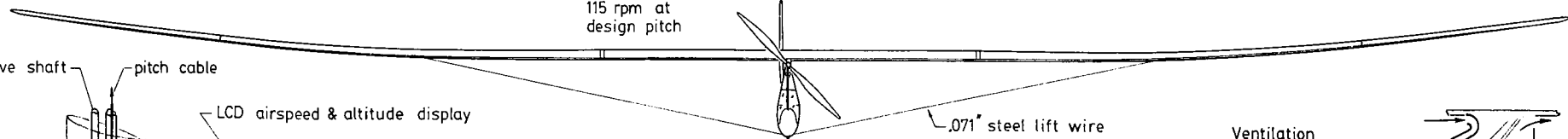

Ventilation Ducting

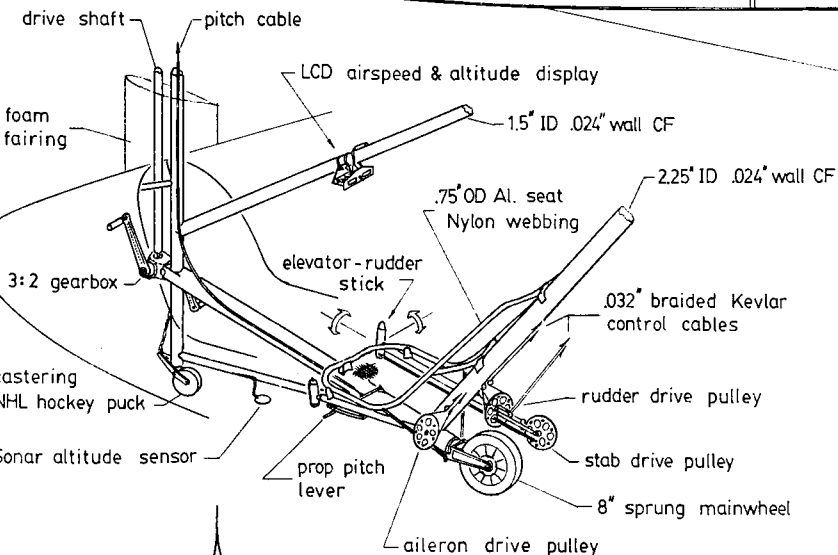

FAI WORLD RECORD
 Closed course distance
 36.4 miles 2 hr. 14 min.

- Empty weight 92 lb.
- Gross weight 242 lb.
- Span 114 ft.
- Wing area 330 sq.ft.
- Cruise speed 14-18 mph
- Pilot power ~0.30 hp

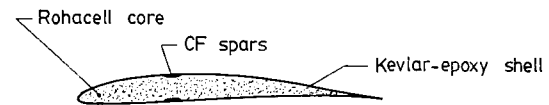

PROP SECTION: DAI 0735

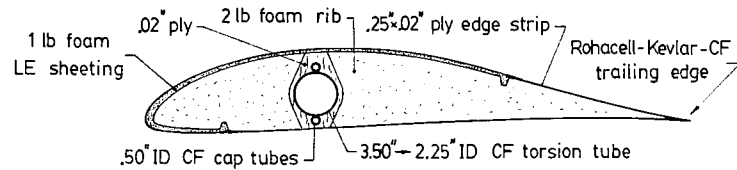

WING CENTER SECTION: DAI 1335

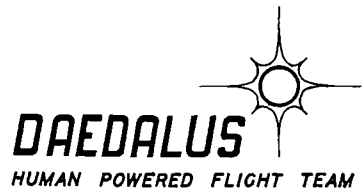

Mad. Dubs 28 Feb 87

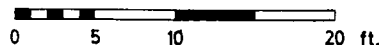

MICHELOB *Light Eagle*